



**COMPLETE FEED  
MILLS, PLANTS  
AND MACHINES**



**AMANDUS KAHL – WORLDWIDE.  
SINCE 1876**

# EXPERTISE IN FEED TECHNOLOGY

*AMANDUS KAHL HAMBURG, founded in 1876, is a medium-sized family-owned company. Complete feed mills, plants and machines are sold all over the world.*

Hydrothermal treatment and hygienization in compound feed plants are the speciality of AMANDUS KAHL. Constant innovations set us apart. Research and development, synergies with institutes and universities as well as the dialogue with our international customers are essential functions of our company.

Our services include extensive engineering from design to assembly and a worldwide network of agencies, service technicians, subsidiaries and sales offices. Systematic and extensive investments in modern machining centres ensure not only our location in Germany, but also the high quality of our plants

and machines, our productive efficiency and production acceleration. This has a direct impact on the satisfaction of our customers and employees.

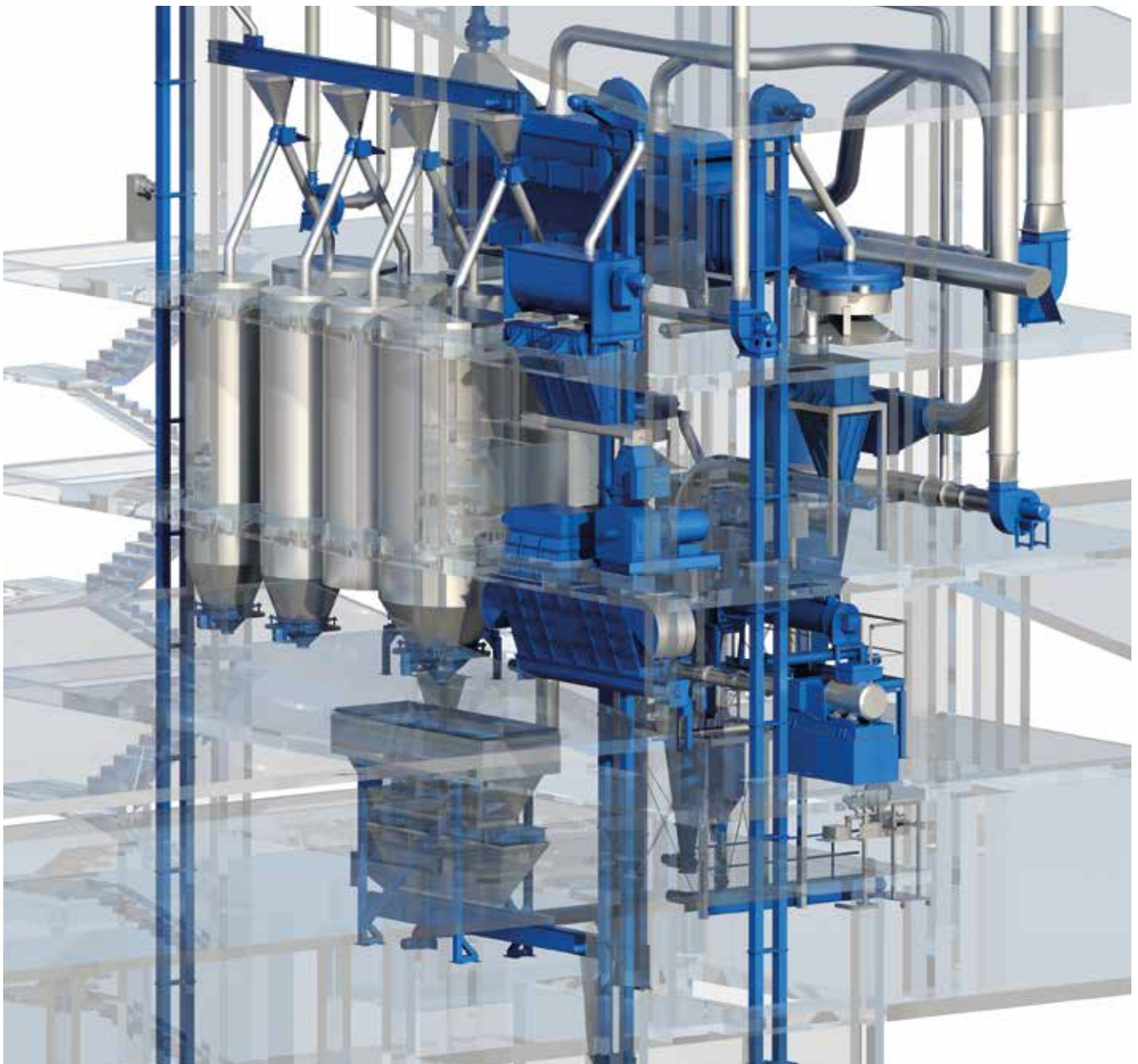

## KAHL ANNULAR GAP EXPANDER – FOR HIGH-QUALITY FEED

### FOR ANIMAL-FRIENDLY FEED

Outstanding product properties have made the KAHL annular gap expander a success.

EXPANDAT® ensures an improved feed conversion and excels by its high quality.

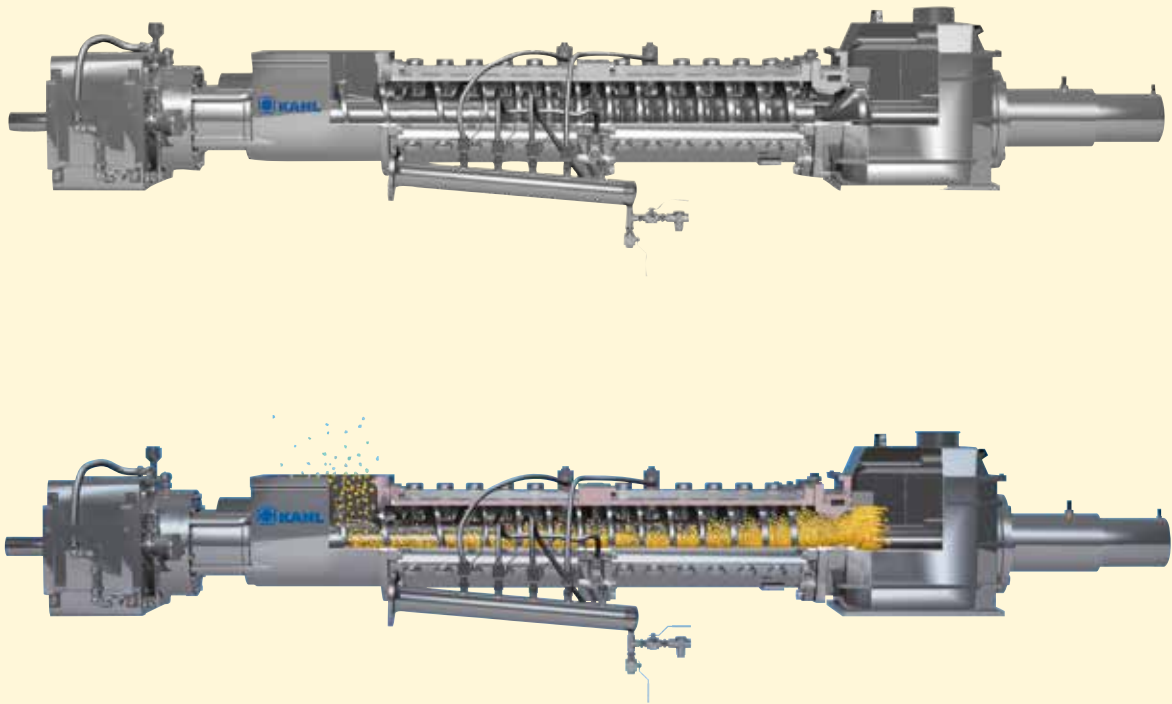

KAHL Annular Gap Expander

#### ADVANTAGES

- *Hygienic, biological, structurized, homogeneous*
- *Granular structure that meets the animals' needs*
- *Excellent flow properties*
- *Quickly soluble in water*
- *Free from pathogenic germs and fungi*
- *Free from salmonellae*



#### Structurized feed

Compared to traditional pellets, the outstanding qualities of expanded structurized feed, whether coarsely crushed or finely granulated, represent an alternative feeding strategy.



#### Pellets from Expandat®

absorb larger quantities of liquid compared to traditionally produced pellets.

## KAHL CROWN EXPANDER – EXPANDING AND SHAPING

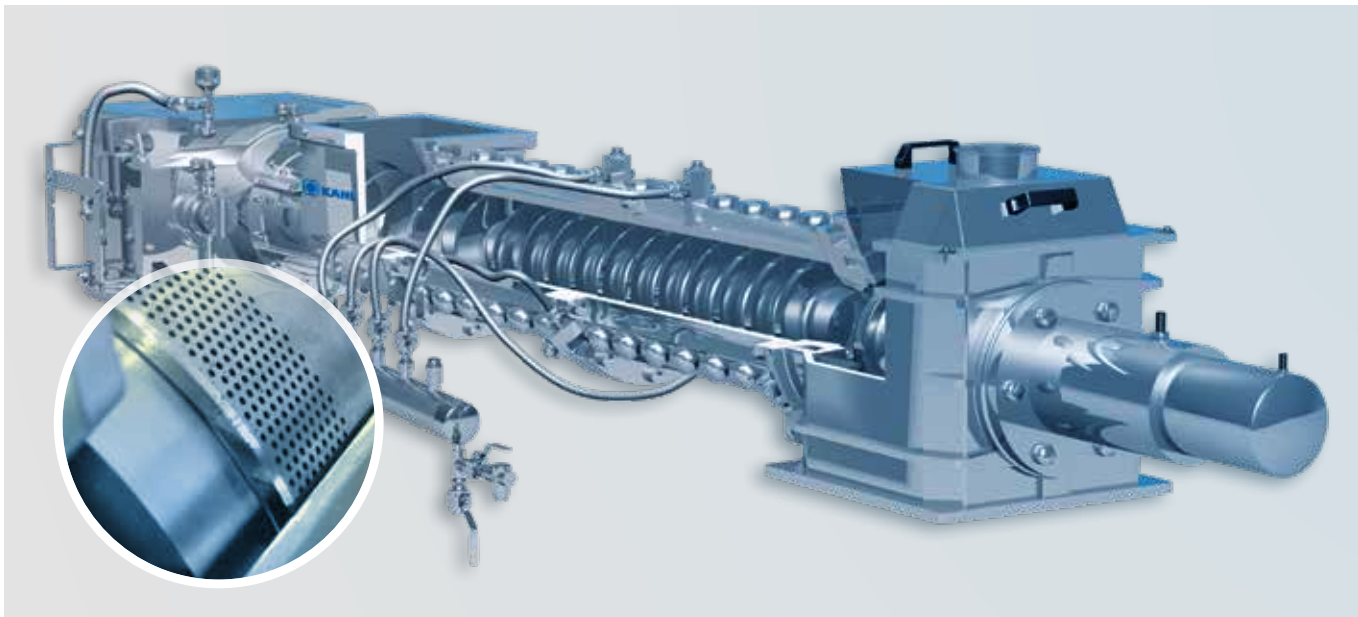

### ADVANTAGES

- Expanding with additional shaping
- Easy processing of feed mixtures, also of mixtures which are difficult to process or which cannot be pelleted
- Significant improvement of the flexibility of expansion (SME control with hydraulically adjustable cone)
- Coarse particles remain coarse, contrary to traditional pelleting
- Very high starch modification possible
- Low energy consumption
- High throughputs
- Different product diameters
- Production of feed for all animal species

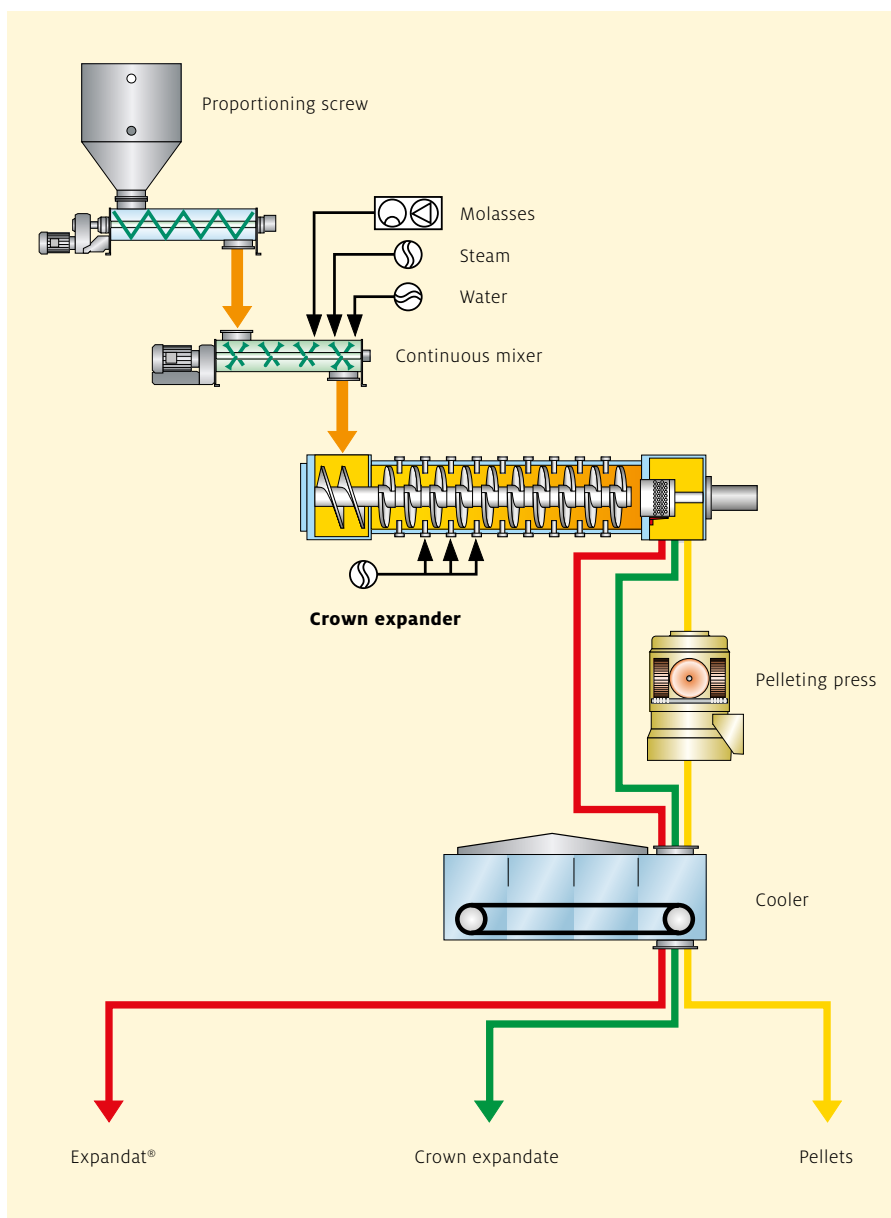

## EXTRUDER TECHNOLOGY FOR THE PRODUCTION OF FISH FEED AND PETFOOD

In the outlet area, the KAHL extruder OEE is equipped with a hydraulic die which can be moved in or out. Machine power is regulated by extension of the hydraulic ram which can be quickly withdrawn in the event of overcurrent. The die change is carried out by means of hydraulic actuation thus is quick and efficient. The knife head is provided with a separate drive and remains in its position during the die change. At the start of the production, the KAHL extruder OEE does not require an increased water addition and can be started with an "open" die. It is less sensitive and the quantity of wasted product is reduced considerably compared to traditional extruders.



Conditioner and extruder in a fish feed plant

### ADVANTAGES AND OPTIONS

- *Precise proportioning of solid matter, steam, and liquids*
- *Optimum product conditioning*
- *Coating system*
- *Gentle drying*
- *Energy recovery and odour reduction*

The machine is equipped with a heating and cooling jacket and, depending on the type of product, with a pile-up disk as well as a pressure and temperature measuring device. The product quality can be essentially influenced by the following process parameters:



### PROCESS PARAMETERS

- *Grinding degree of the raw material*
- *Conditioning*
- *Selection of additives*
- *Mechanical energy input (e.g. the starch gelatinization and thus the product quality can be influenced by means of the energy input)*
- *Die geometry (product design)*
- *Also for special applications*

# KAHL PELLETING PRESSES – ROBUST AND POWERFUL

Whether small, medium or high capacities – no problem for our flat die pelleting presses, which have proven their worth for decades, even for feed mixtures which are very difficult to process.

### ROBUST, POWERFUL, AND VERSATILE

- KAHL builds economic high-quality flat die pelleting presses
- Top-quality pellets with a diameter of 2 to 40 mm can be produced with these presses
- The product is formed into endless strands which are precisely cut by means of knives.
- With a roller speed of only 2.5 m/s an optimum deaeration of the product is achieved
- The plants are extremely silent with a noise level of less than 70 dbA
- 12 types of pelleting presses are available for different applications

### FIELDS OF APPLICATION

- *Compound feed for all animal species*
- *Raw components*
- *Mineral mixtures*
- *By-products of the food industry*
- *Dried forage*
- *Straw and mixtures with a straw content*
- *Biomass*



Pelleting press, type 14-175, for small-scale production



Long-fibre pellet with high straw content

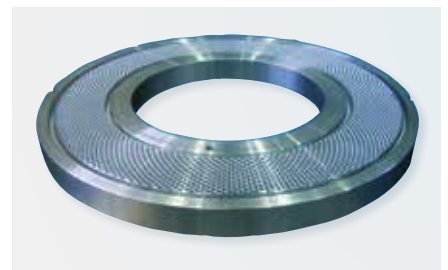

Flat die



Pelleting press in a compound feed factory

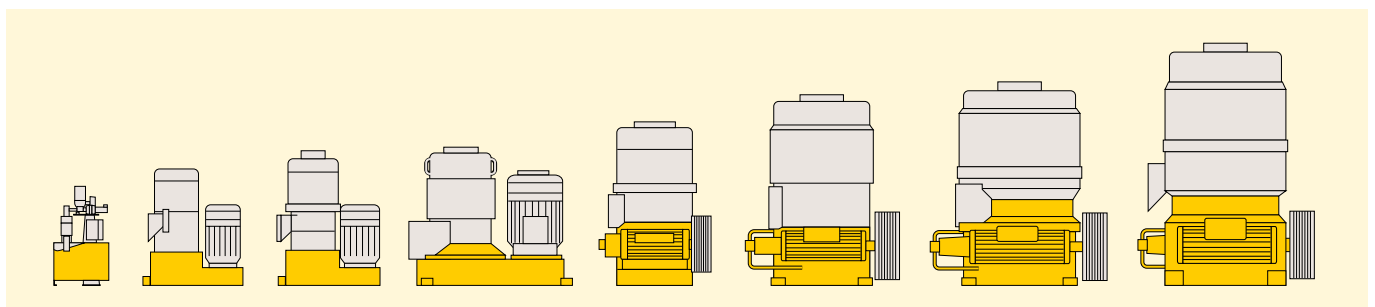

# KAHL PROCESS CONTROL – AUTOMATED OPERATION

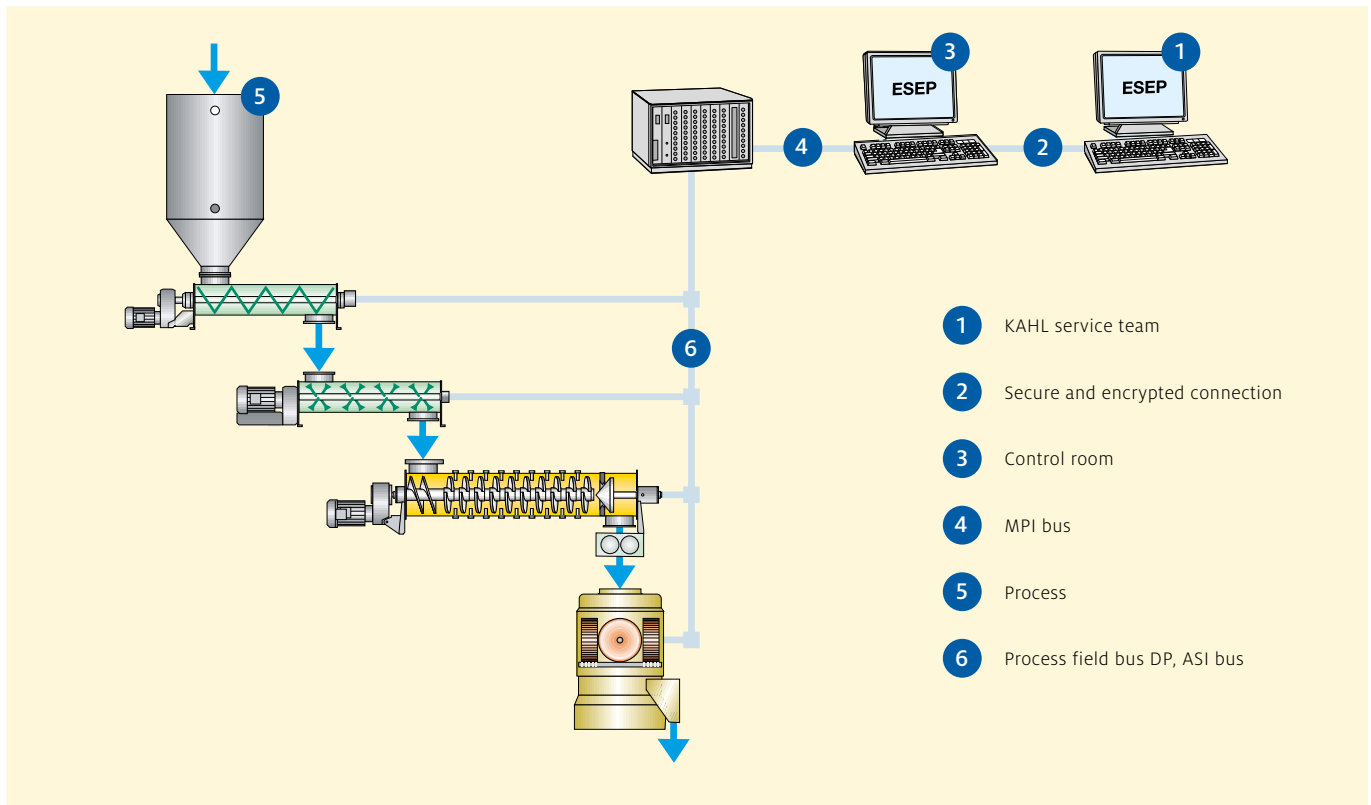

**THE PROCESS IS OPTIMISED BY MEANS OF THE AUTOMATIC CONTROL SYSTEM EAPR AND THE AUTOMATIC DISTANCE CONTROL DISTAMAT**

- Automation of the complete production line
- Constant product quality at high throughput
- Lower manpower requirement
- Up to 3 lines on a PC
- Improved monitoring of the production process
- High availability due to the use of proven quality components
- High process flexibility, adjustable and extensible without any problems
- Rapid and economic commissioning
- Field bus system saves installation costs

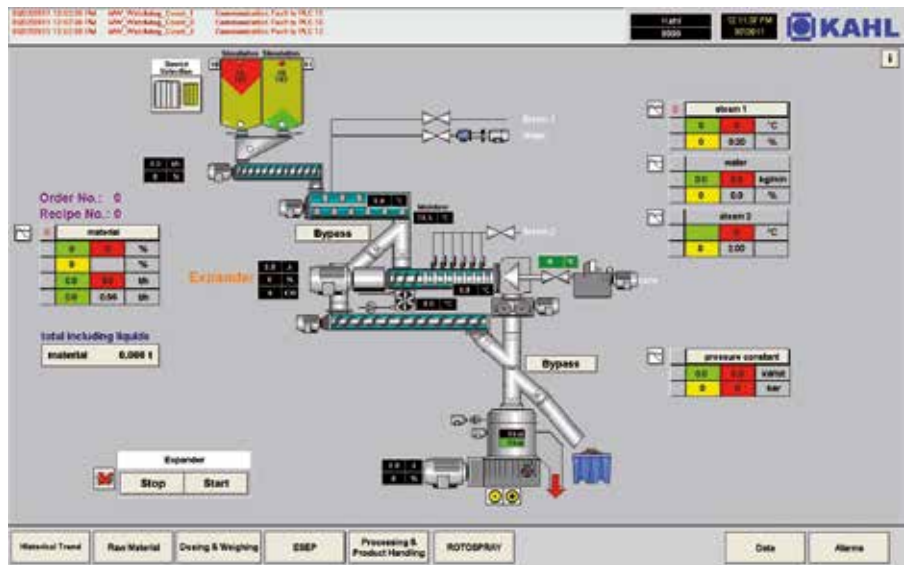

Sophisticated machines such as the annular gap expander and the pelleting press require an appropriate control system. For this reason, the ESEP (Electrical control System of the ExPander) and the EAPR (Electrical Automatic system for Presses) have been developed by the company KAHL. The individually pro-

grammed control of a complete plant or the automation of complete production lines also belongs to our range of services. We have our own switch cabinet manufacturing department.

## KAHL BELT DRIER/COOLER

### GENTLE DRYING AND COOLING

KAHL belt units dry and cool pellets without the formation of cracks.

- Convictional cooling provides heat exchange between product and air
- Evaporative cooling removes water from the product
- The cross and counter-current principle is efficient

### CUSTOM-MADE UNITS THANKS TO MODULAR DESIGN

By means of modular design, the size and the process technology of the plant can be exactly adapted to the particular requirements. Subsequent extension of the plant is also possible.

Depending on the demands, ambient air or recirculated air with a temperature of up to 200 °C are used in KAHL belt units. Inert gas designs avoid emissions and dust explosions.

The feeding device is adapted to the pellets' consistency. A special fabric belt is available for pasty products.

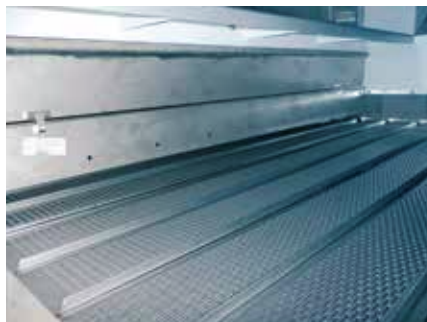

### ADVANTAGES

- 2 – 350 m<sup>2</sup> process surface in modular design
- Small and large units are assembled in modular design
- Subsequent extensions and additional storeys are possible
- Three standard widths are available
- Special widths can be supplied
- More than 1,000 KAHL belt units are now in operation worldwide

## KAHL ROTOSPRAY®

### COST-SAVING MICRO-SPRAYING SYSTEM

1 millilitre of liquid is diffused into approx. 10,000,000 droplets.

With this spraying system, liquids and micro-components are added without pressure.

The main part of the system is a rotation nozzle which allows an ultra-fine spraying of the liquids.

The special distribution of the solid matter flow ensures spraying of the product from all sides.

Examples of products: Enzymes, vitamins, oils and many more.

### ADVANTAGES

- Low space requirement
- Automatic adjustment of the liquid flow to the solid matter flow
- Undiluted spraying
- No residual liquid quantities
- No spoilage
- Insensitive to dust
- No danger of clogging
- Unpressurized liquid supply
- Economical application



Caption: ROTOSPRAY®, type 700 (for high capacities)



## KAHL CRUSHING ROLLER MILL – EFFECTIVE FOR HIGH-QUALITY PRODUCTS

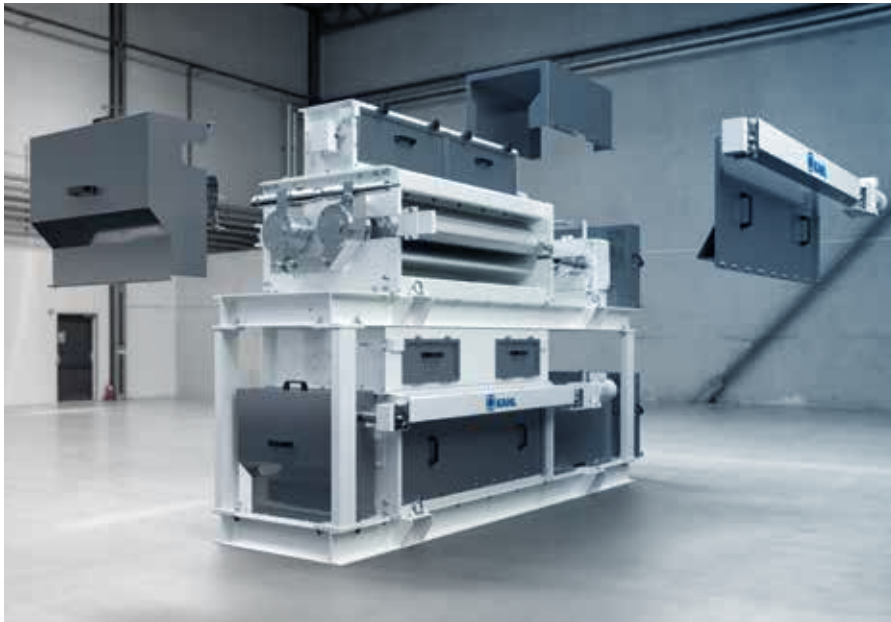

Using the KAHL crushing roller mill cereals, legumes, oilseeds, and feed mixtures can be crushed efficiently and with a considerably lower expenditure of energy compared to the hammer mill. Our chilled cast iron rollers are available in four sizes.

### HIGH-QUALITY PRODUCTS

Animal feed for pigs, poultry or cattle produced in the KAHL crushing roller mill offers advantages in animal nutrition:

- Improved digestion
- Fewer diseases
- Better meat quality
- Better housing environment

### ADVANTAGES

- *Narrow particle size distribution*
- *Simple roller gap adjustment*
- *About 50 % lower power consumption than hammer mills*
- *Reduced wear*
- *Smooth operation*
- *Simple roller change*

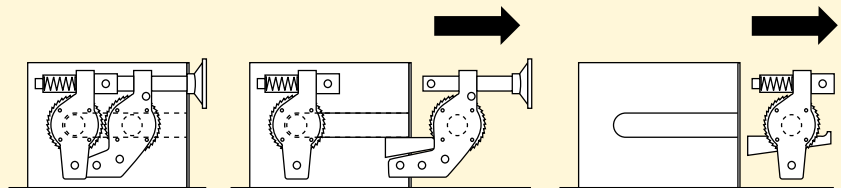

Simple roller change without removal of the drive elements



### CATTLE FEED

A coarse structure reduces the starch degradation in the rumen, the pH-value remains stable, optimum utilisation of the genetic performance.



### PIG FEED

No stomach diseases, high feed consumption, high fattening yields, drier manure.



### POULTRY FEED

No feed selection, longer retention time in the intestine, drier manure, better housing environment, high meat quality, high egg yield.

# HYDROTHERMAL REACTOR FOR SOYBEAN AND RAPESEED TREATMENT

## HYDROTHERMAL REACTOR

The reactor is suitable for improving the product characteristics and for reducing harmful components inhibiting digestion: urease, trypsin, phasins, glucosinolates, gossypol etc.

A careful and uniform product treatment is achieved by means of temperature, moisture, retention time, and mechanical treatment which can be controlled separately.



## KAHL STANDS FOR MAXIMUM QUALITY

### PROFESSIONAL IMPLEMENTATION OF INNOVATIONS

The KAHL pilot plant is an example of the professional way of working to the benefit of our customers. The pilot plant helps you to steadily optimise your products and processes.

Market requirements, product trends and process developments are investigated and advanced.

We offer decades of experience in test engineering. In our pilot plant, a comprehensive test data base with more than 2,000 products from our international customers and prospective buyers is available. Bespoke tests can

be carried out with a few kilograms or several tons of product in our laboratory and pilot plant – according to your particular requirements. Process know-how, machines and plants as well as modern analysis instruments for quality assurance are at your disposal. Furthermore, we co-operate closely with renowned institutes. On the basis of the obtained results, plant designs and offers can be prepared individually. As a matter of course, we ensure utmost confidentiality towards our customers and prospective buyers.



### Planning and projecting

The knowledge obtained from the tests are considered in the planning and projecting, when it comes to the proper plant design



### Modern production

AMANDUS KAHL has 11 production halls. All main machines are produced in Reinbek near Hamburg – they are Made in Germany



### Spare parts service and support

To best serve our customers and respond to their individual requirements, we offer a wide variety of after-sales services

# KAHL EXPERTISE FOR TURN-KEY FACTORIES



## WORLDWIDE ON THE ROAD TO SUCCESS

AMANDUS KAHL today looks back on more than 140 years of machine and plant construction. In 1920, the first pelleting press designed as a worm extruder was produced. The range of products is advanced permanently. In 1991, the KAHL Group was founded.

## KAHL SERVICES

Process technology, engineering, machines, plants, turnkey factories. Worldwide branch offices and agencies and worldwide service.

## KAHL PLANTS

Turn-key feed mills and plants for compound feed, shrimp and fish feed, pet food, premix / concentrate, roughage, straw, green forage, dried beet pulp, wood and biomass, recycling plants for waste tyres, household and industrial waste and composting plants.

## KAHL MACHINES

Proportioning and weighing equipment, mixers, hammer mills, liquid proportioning units, continuous mixers, conditioners, hydrothermal reactors, sterilizers, annular gap expanders, extruders, pelleting presses, driers/coolers, crumblers, Rotospray®, control and process visualisation systems.



