

# Pelleting Press 14 - 175



## Pelleting press for small-scale productions

The pelleting press can be used for

- Testing the pelleting qualities of a diverse range of products,
- Production of test material in research laboratories,
- Tests to obtain optimal formulations for achieving economic pelleting,
- Pelleting of high quality materials in smaller quantities.

The laboratory press operates on the flat die principle which has a proven value with difficult materials.

The pelleting tools can be easily interchanged without the need for special equipment.

Small quantities are manually fed by way of a feed hopper. For continuous operation a proportioning feed unit is fitted to the press.



The flat die pelleting presses are suitable for compacting powdery and lumpy products.

Machine design:  
Jens Plewa vom Berg,  
Hamburg

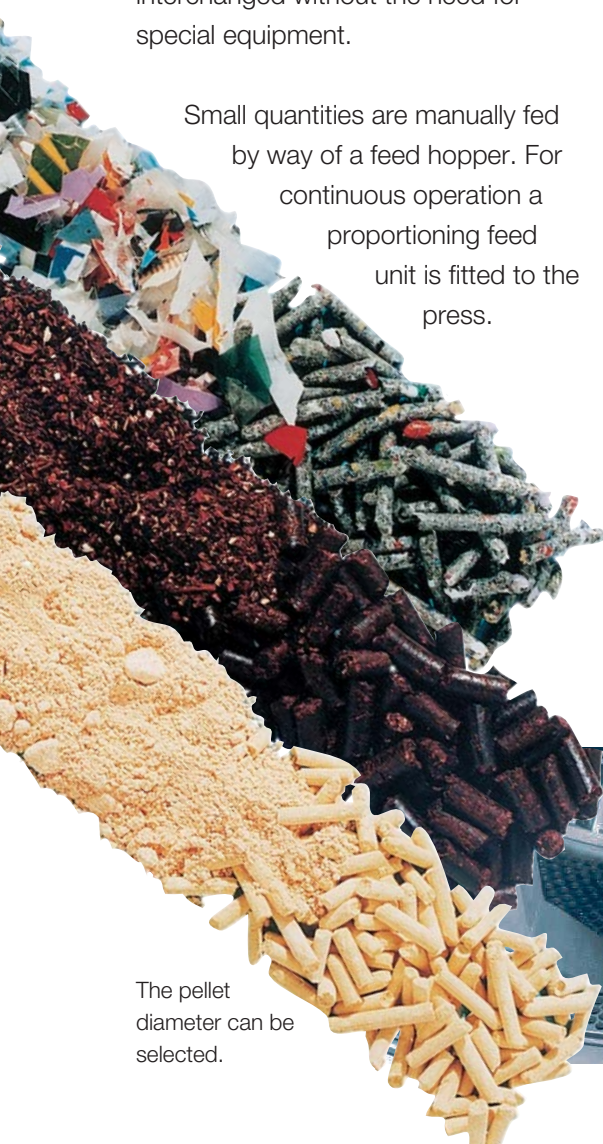

The pellet diameter can be selected.

Positive roller drive

- optional extra for products with high anti-friction properties.



Press Typ 14 - 175

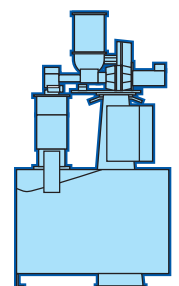

The range of KAHL pelleting presses comprises 12 sizes which cover laboratory requirements through to high capacity production.

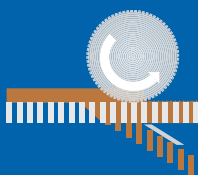

# Pelleting Press 14 -175

## Technical data

The drive is continuously adjustable by means of a geared motor with frequency converter.

All bearings are provided with maintenance-free seals and permanent lubrication.

The press, drive, and control equipment are supplied in one integral unit so that the only installation requirement is an electrical power feed.

Die diameter	175 mm
Pan grinder roller width	29 mm
Drive motor power	3 kW
Weight	260 kg

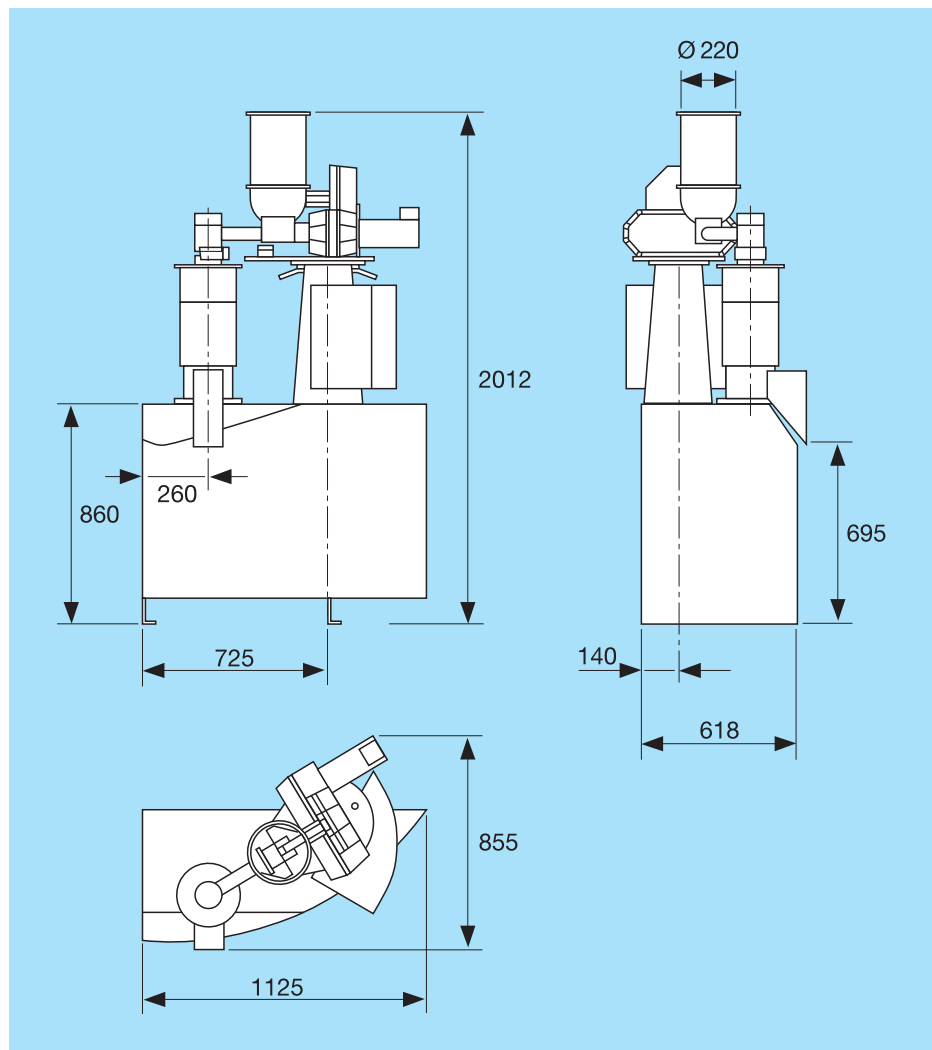

**AMANDUS KAHL GmbH & Co. KG**

Dieselstrasse 5-9

D-21465 Reinbek / Hamburg

Phone: +49 (0)40 727 71 - 0

Fax: +49 (0)40 727 71 - 100

info@amandus-kahl-group.de

[www.akahl.de](http://www.akahl.de)