

# Press O-500/390 for the Granulation of Pasty Food

Granulation (pelleting) of raw materials, and finished products can be achieved economically utilizing our "horizontal flat die extrusion press" compacting system.

For processing pasty products, the type O series = overhead drive has been developed.

As an example, these presses are appropriate for the granulation of food components in powdery, lumpy or pasty form, drink powder, spices, chocolate mass, and instant vitamin C products.

Directly after leaving the die, the pellets can be fed onto a conveying element – free from mechanical stress. Therefore clogging of the discharge devices as with standard presses and agglomerations of the pellets are avoided.

The press is made of stainless steel and works on the well-proven flat die principle.

Main machine bearings and roller bearings are provided with a long-term lubricant and with special seals.

(Cutting device available as an optional extra)

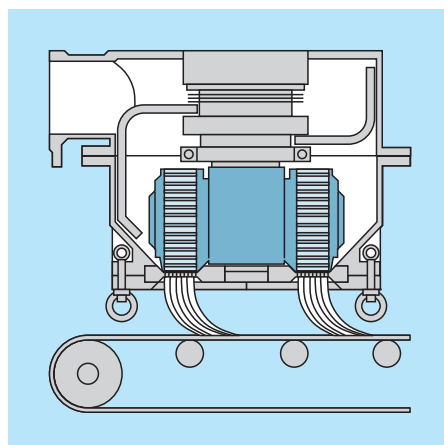
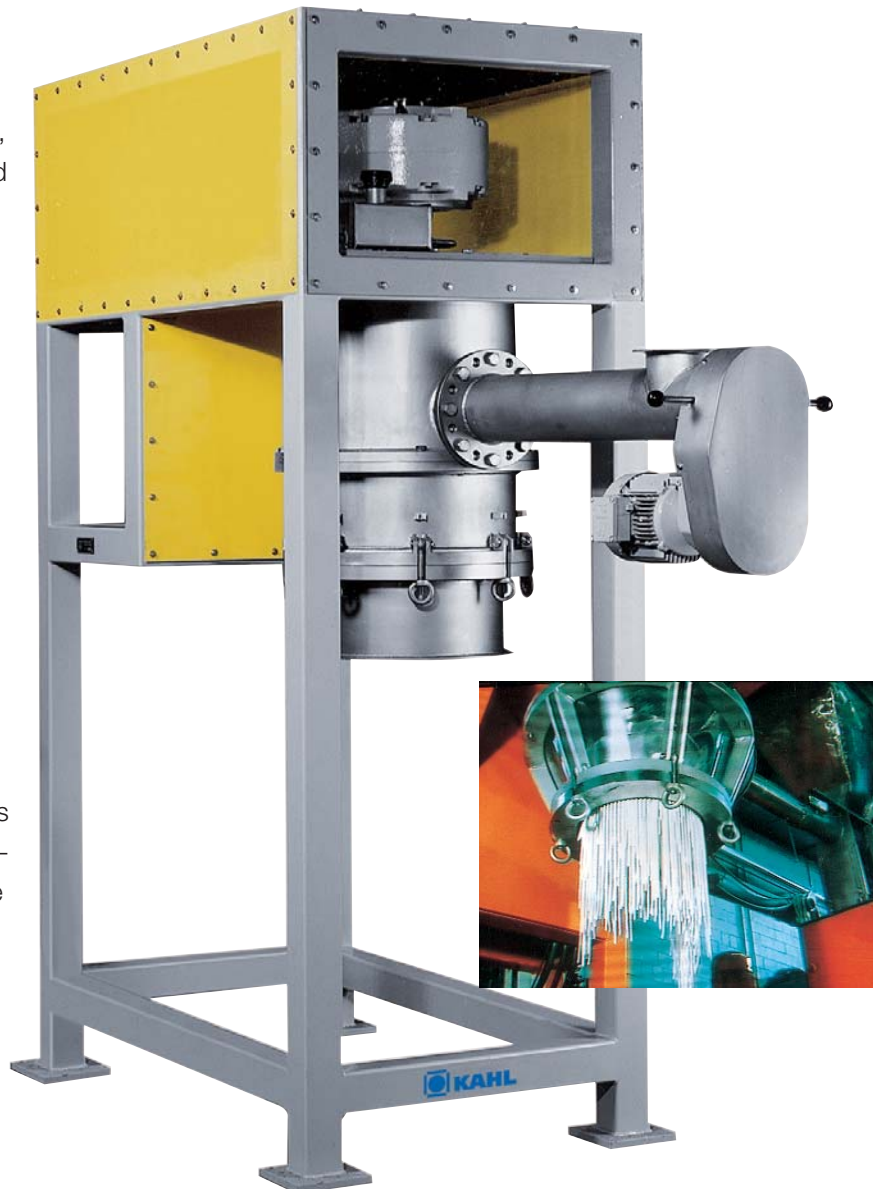

Press with overhead drive

## Pelleting presses

The range of KAHL pelleting presses consists of 12 sizes which cover laboratory requirements through high capacity production needs.

# Press O-500/390

## Technical data

### Pellet diameter

0.6 - 15 mm

0.6 - 2 mm (only with perforated plates)

2 - 15 mm (only with dies)

The press is driven by a three-phase current motor, a V-belt drive, and a slip-on gear.

### Hydraulic system of the pan grinder head

The pan grinder head is equipped with a hydraulic pan grinder head adjustment. With this system, the distance between rollers and die can be modified during operation. Thus the thickness of the product layer can be influenced and adapted to the requirements of the product.

### Technical options

- Roller drive for products with extreme slipping properties
- Roller gap control unit for products with high quality demands
- Inner die support to absorb the pressure forces at the inner ring of the perforated plates/dies

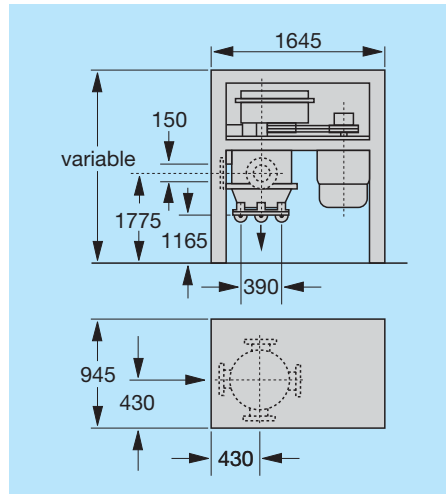

**Type 24-390**

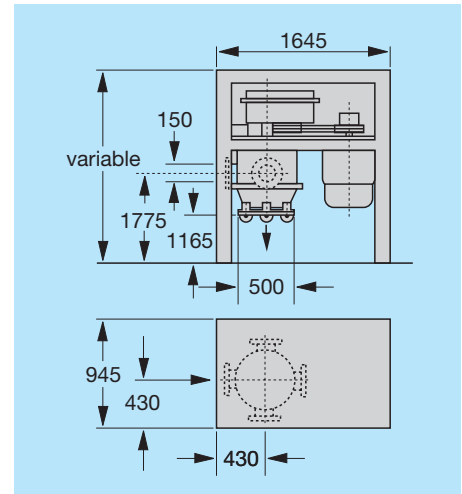

**Type 25-500**

Die diameter	390 /500 mm
Roller diameter	230 mm
Roller width	77 mm
Number of rollers	2/3
Drive motor	22 – 30 kW
Circumferential roller speed	1.5 to 3.0 m/s
Machine weight	
with motor, gear and support frame	2000 kg

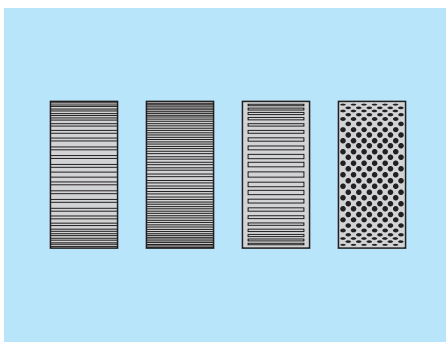

Product-dependent roller profiles

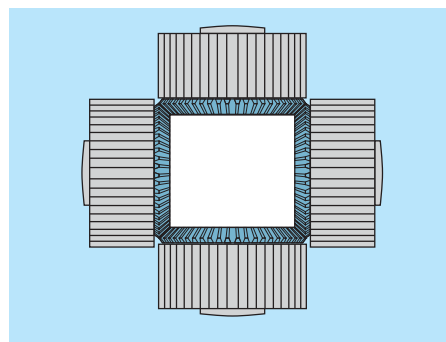

Positive drive for products with extreme slipping properties



### AMANDUS KAHL GmbH & Co. KG

Dieselstrasse 5-9

D-21465 Reinbek / Hamburg

Phone: +49 (0)40 727 71 - 0

Fax: +49 (0)40 727 71 - 100

info@amandus-kahl-group.de

[www.akahl.de](http://www.akahl.de)