

Proportioning and conveying screws in modular design



The conveying screws serve for continuous transport of bulk material in horizontal or ascending direction. The simple design and low maintenance requirements of the conveying screws contribute to their high operational reliability. The screw troughs with removeable covers are executed in a stable construction.

The troughs, in the standard lengths of 1500, 2000, 2500, 3000 mm, are connected with each other by means

of flanges. Special trough lengths are available.

The worm shaft consists of a tubular shaft with welded-on solid thread made of sheet steel. It runs on antifriction bearings with stuffing box sealings. In case of larger lengths maintenancefree intermediate bearings are used.

The tubular shaft parts are connected by means of bolts. The inlets and

outlets can be arranged according to requirement.

The screws are driven by offset geared motors. If sufficient space is lacking, other drive types are possible, too.

Designs:

- Controllable proportioning screws
- Conveying screws
- Thread types: solid blade thread, belt thread, paddle thread

Proportioning and conveying screws

The arrangement of the inlets and outlets, the thread type, and the direction of rotation depend on the local conditions.

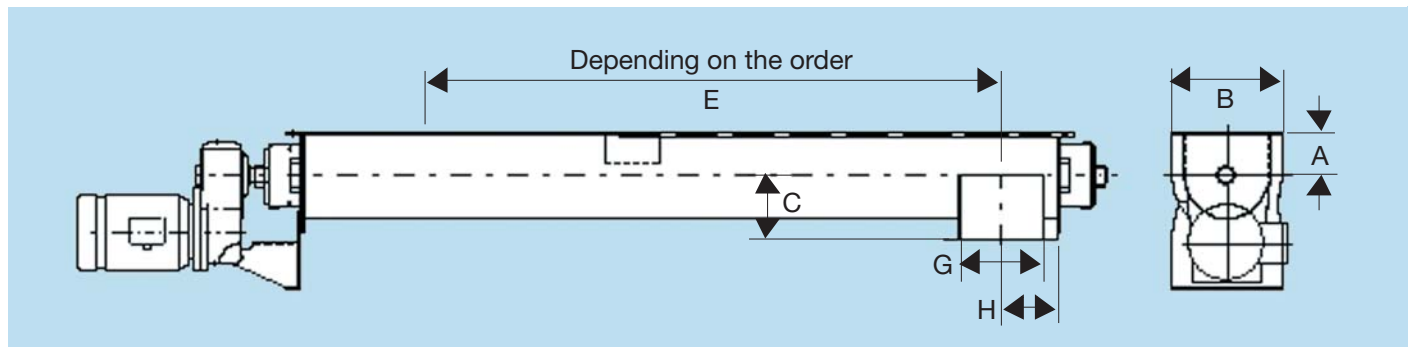

Screw diameter Ø	125	160	200	250	315	400
Height "A" mm	75	90	112	140	180	224
Width "B" mm	204	255	295	355	440	535
Height of outlet "C" mm	115	150	170	199	220	340
Clear width of trough	140	180	220	270	335	425
Outlet opening "G" mm	140	180	220	270	335	425
Dimension "H"	130	150	150	170	220	250
Drive length	Depending on drive type and size					

The following examples show the 4 most frequent designs

- 1 Right-hand thread, anticlockwise rotation, conveying away from the drive.
- 2 Right-hand thread, clockwise rotation, conveying towards the drive.
- 3 Right-hand and left-hand thread, clockwise rotation, conveying from the centre to the ends.
- 4 Right-hand and left-hand thread, anticlockwise rotation, conveying from the ends to the centre.

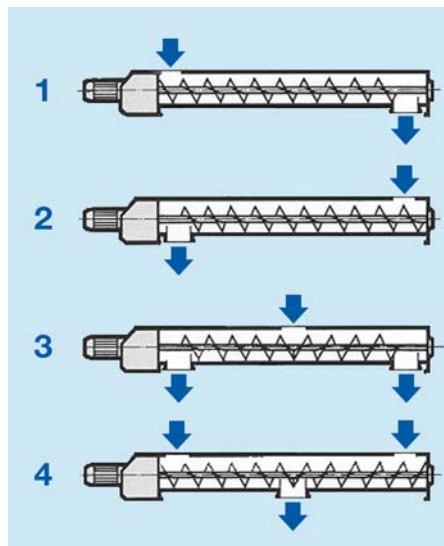

Special accessories:

- Speed sensor,
- Product detector,
- Air shut-off flap



AMANDUS KAHL GmbH & Co. KG

Dieselstrasse 5-9

D-21465 Reinbek / Hamburg

Phone: +49 (0)40 727 71 - 0

Fax: +49 (0)40 727 71 - 100

info@amandus-kahl-group.de

www.akahl.de